

# V6842-TA Series

## 2MP Vandal Resistant Low Light IP

### Minidome Camera

**Infinova**<sup>®</sup>  
The Integrator's Manufacturer

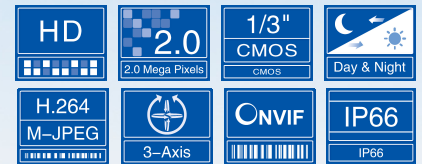

- **1/3" progressive scan CMOS sensor**
- **IR-Cut Removable (ICR) Filter for Day/Night switching**
- **Support auto exposure, AWB, auto focusing**
- **Motorized zoom lens for auxiliary Focus**
- **Supports P-IRIS function**
- **Supports WDR function**
- **ONVIF-compliant**
- **Sensitivity: 0.005 lux**
- **High-resolution image signal output: 1920×1080@30fps**
- **Three Simultaneous Video Streams: Dual H.264 & scalable M-JPEG**
- **Bi-directional audio**
- **Motion detection, privacy mask**
- **1 alarm input, 1 relay output**
- **local recording**
- **Supports storage with TF card**
- **Multiple ways to handle alarms**
- **Easily incorporated with other video surveillance software**
- **Surface Mount and Pendent mount optional, 3-axis adjustment**
- **IP66 environmental rating**
- **Rugged design (IK10)**

V6842-TA series HD megapixel low light IP minidome camera features 1/3" progressive scan CMOS sensor and built-in HD megapixel 3.0-9.0mm lens. With H.264 High profile/M-JPEG video compression format utilized, this series can output the real-time images with the resolution up to 1920×1080@30fps.

With the built-in motorized zoom lens, the camera can focus clear rapidly. Besides, the camera supports motion detection functions, which are able to link with alarm to store and snapshot images. Privacy mask can protect certain private area from being seen by operator.

V6842-TA series minidome camera is suitable for financial institutions, telecommunications, governments, schools, airports, factories, hotels, museums, city streets and other high-resolution surveillance applications.

## Technical specifications

Image Sensor	1/3" progressive scan CMOS
Dynamic Range	72.4dB
Lens	Motorized zoom lens, F1.2, f=3.0-9.0mm
P-IRIS	Available
Camera Angle Adjustment	X (Panning): 0°~360°; Y (Tilting): -75°~75°; Z (Rotating): 0°~360°
Day/Night Functionality	ICR
Sensitivity	Color mode: 0.01 lux @ F1.2 (30IRE, AGC ON); B/W mode: 0.005 lux @ F1.2 (30IRE, AGC ON)
Shutter	Auto
White Balance	Auto/Incandescent/ Fluorescent/Daylight/ Sunny/ Cloudy/ Outdoor/Manual
Gain Control	Auto
Noise Reduction	3D
Video Compression	H.264 High profile/M-JPEG
Maximum Resolution	1920×1080@H.264 major stream/M-JPEG D1@H.264 minor stream
Maximum Frame Rate	30fps@1920×1080
Data Rate	Variable bit rate; Constant bit rate: 1024Kbps~24576bps(H.264 major stream) 256Kbps~8192bps (H.264 minor stream)
Audio	Audio Compression: ADPCM/PCM/G726; 1 input (Linear level, Resistance: 1000 Ohm), 1 output (Linear level, Resistance: 600 Ohm)
Privacy Mask	Up to 4 masks
Motion Detection	Up to 4 areas
Local Recording	Available
TF Card Storage	Available, up to 32G
Upgrade Online	Available

Password Protection	Available
Alarm	1 alarm input, 1 relay output
Network Port	One RJ45 10/100M self-adaptive Ethernet port
Applicable Protocols	IPv4, TCP, UDP, IGMP, DHCP, FTP, SMTP, NTP, RTP, RTSP, RTCP, HTTP, HTTPS, TSL, SSL, 802.1X, QoS, DNS, ARP, ICMP
Power Supply	PoE/24VAC
Power Consumption	<12W (W/heater)
Operating Temperature	-40° F ~ 140° F (-40° C ~ 60° C)
Storage Temperature	-4° F ~ 140° F (-20° C ~ 60° C)
Operating Humidity	0%-90% RH (non-condensing)
Unit Dimensions (H×Ø)	Surface: 5.08"×5.91" (129mm×150mm); Bracket: 8.35"×7.13" (212mm×181mm)
Box Dimensions (L×W×H)	Surface: 8.03"×7.48"×7.13" (204 mm×190 mm×181mm) Bracket mounting adapter: 9.21"×8.66"×7.24" (234 mm×220 mm×184 mm)
Unit Weight	Surface: 2.73lbs (1.24Kg) Bracket mounting adapter: 1.41lbs (0.64Kg)
Shipping Weight	Surface: 3.26lbs (1.48Kg) Bracket mounting adapter: 2.20lbs (1Kg)
Impact Resistance	IK10
<b>Certifications and Approval</b>	
Product Certifications	CE/EMC: EN 55022, EN 55024, EN 61000-3-2, EN 61000-3-3 <sup>1</sup> , FCC: Part 15 Subpart B Class A <sup>2</sup> , UL 60950-1 <sup>3</sup> , ISO 9001:2008

Certificate No.: <sup>1</sup>CTL1411062679-EC; <sup>2</sup>CTL1411062679-FC; <sup>3</sup>E232008-A43-UL

## Ordering information

- V6842-TA220SF HD Megapixel IP minidome camera, Vandal-resistant, 3-axis, Day/night, 1/3 inch CMOS sensor, H.264/M-JPEG, 2.0 Mpx, PoE/24VAC, Surface mount, 3.0-9.0mm motorized zoom lens
- V6842-TA220PF HD Megapixel IP minidome camera, Vandal-resistant, 3-axis, Day/night, 1/3 inch CMOS sensor, H.264/M-JPEG, 2.0 Mpx, PoE/24VAC, Bracket mount, 3.0-9.0mm motorized zoom lens

### ACCESSORIES

#### Power Supplies

- N3922-24A-1 Power Supply, 24VAC, 50VA, Plug-In, 120VAC
- N3922-24A-2 Power Supply, 24VAC, 50VA, Plug-In, 230VAC

#### Mounts for bracket mount model

- V1761MS-W Wall mount, 6 inch horizontal, high gloss white
- V1762MS-W Corner mount, 6 inch horizontal, high gloss white
- V1763MS-W Pole side, 6 inch horizontal, high gloss white
- V1761MA-W surface-to-bracket mounting adapter, high gloss white

For detailed information, please refer to V1760 series Mounts.

## Dimensions

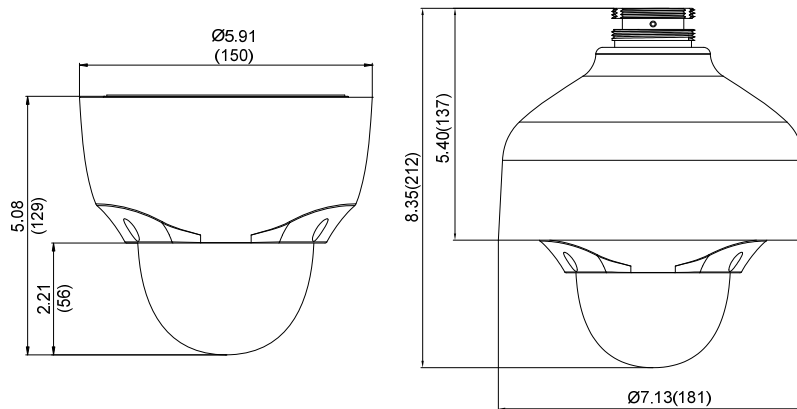

(Unit: inch, in the parentheses is mm)